

TrailerCaddy™

6K Lift - 48v

The Walk Behind, Battery
Powered Trailer Mover.
Move Heavy Trailers With Ease!



Lifts tongue weight up to 6,000 lbs
Pushes or pulls up to 100,000* lbs
Optional Air Brake Release Package Available
**Zero Grade Smooth Surface Rating*

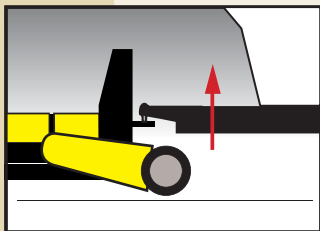

Lifts and Moves Standard
Ball and Pintle Coupler
Trailers.

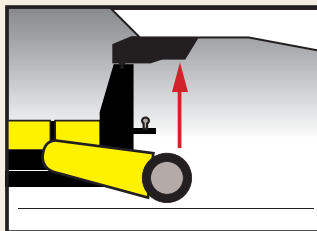

Lifts and Moves King Pin
and Goose Neck Style
Coupler Trailers.

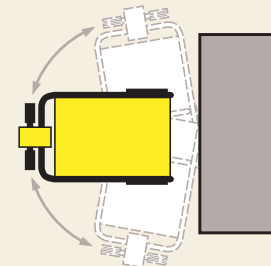

Lifts and Moves Heavy
Campers, Boats, Utility,
Generators or Equipment
Trailers!

DJ PRODUCTS, INC.

1009 4th St. NW, Little Falls, MN 56345 • PH: 800-686-2651 • FAX: 320-632-3553 • www.djproducts.com

TrailerCaddy™

6K Lift - 48v

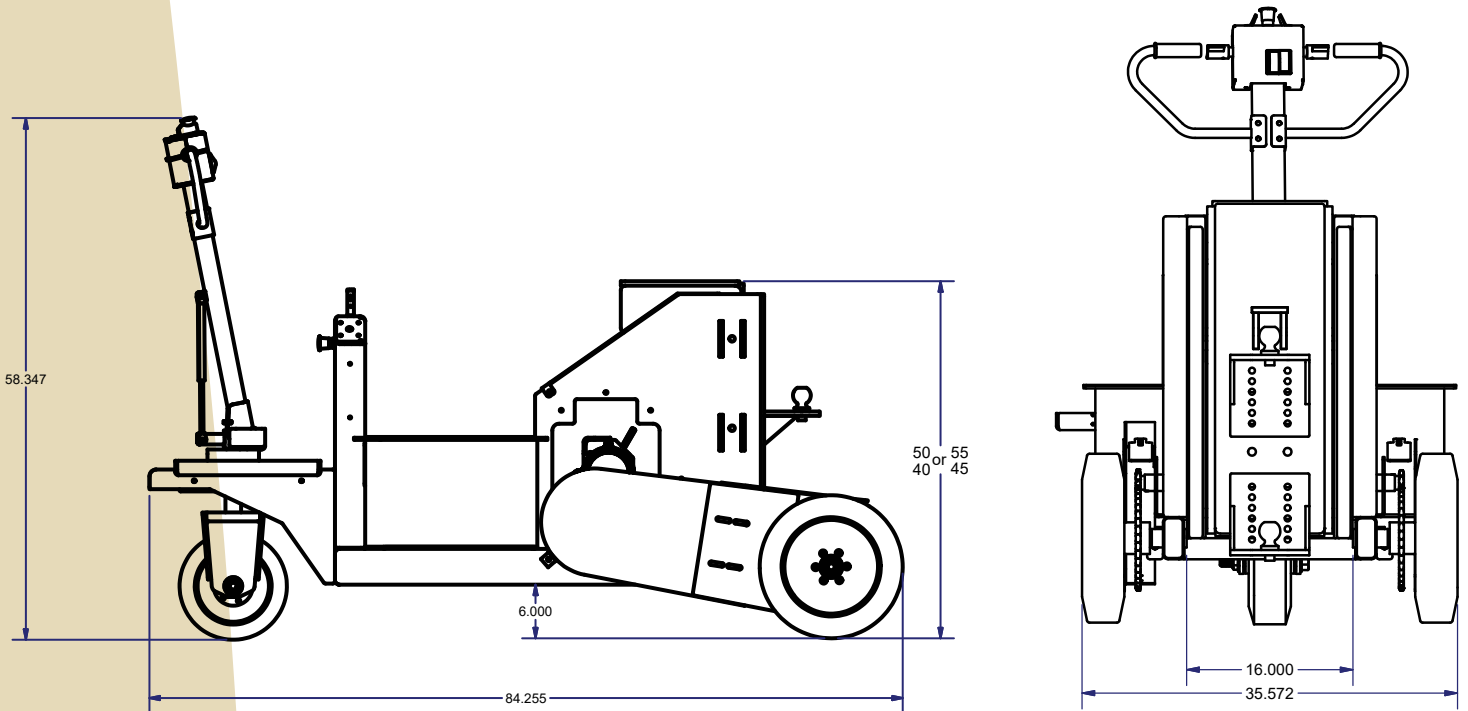

TrailerCaddy 6K Lift - 48v Standard Features

- Heavy Duty Steel Frame
- 48v Transaxle
- 2:1 Gear Reduction with Chain to Drive Tires
- High Tech Speed Controller
- Neutral Throttle Braking
- Adjustable Acceleration/Braking
- 6000 lbs Hydraulic Actuator Lift Kit
- 48v (4) 80 Amp Batteries
- Variable Speed Thumb Twist Pad
- 0-2 mph Forward/ Reverse
- Battery Discharge Indicator
- External Charger
- Safety Stop Switch
- Safety Horn
- (2) 16" Solid Tread Drive Tires
- (1) 12" Solid Thread Steer Tire

TrailerCaddy 6K Lift - 48v Options

TrailerCaddy 6K Lift - 48v

King Pin Attachment for 5th Wheel Trailers

Upgrade to Dual 16" Aggressive Tread Drive Tires
(for lifting loads over 4000 lbs)

Air Break Release Kit
(includes pump motor, 2 cables & 5 gal. air tank)

Pintle Hitch

Ball Hitch and Bracket

Safety Strobe Flashing Light

Upgrade to Maintenance-Free Batteries (set of 4)

Upgrade to Qty: (8) 80 Amp Batteries

Upgrade to Qty: (8) Maintenance-Free Batteries

Upgrade to 110 Amp AGM Batteries (set of 4)

Upgrade to Qty: (8) 110 Amp AGM Batteries
(AGM batteries needed for oversea's shipments)

These options are only recommendations. Please consult a Sales Engineer at DJ Products, Inc. for your specific application. Other options are available.

DJ PRODUCTS, INC.
1009 4th St. NW, Little Falls, MN 56345

Ireland/UK Importer: Brightgreen Recycling Ltd,
Fleenstown, The Ward, Co. Dublin DT11 ET71, Ireland.
Ph: +353 86 3881615 E: aidan@brightgreen.ie

PH: 800-686-2651 • FAX: 320-632-3553

www.djproducts.com