

CarpetCaddy



Battery-powered CarpetCaddy pushes or pulls rolled mats, rugs and carpet up to 1K lbs. while preventing injury

DJPRODUCTS, INC.

1009 4th St. NW, Little Falls, MN 56345 • PH: 800-686-2651 • FAX: 320-632-3553 • www.djproducts.com

CarpetCaddy

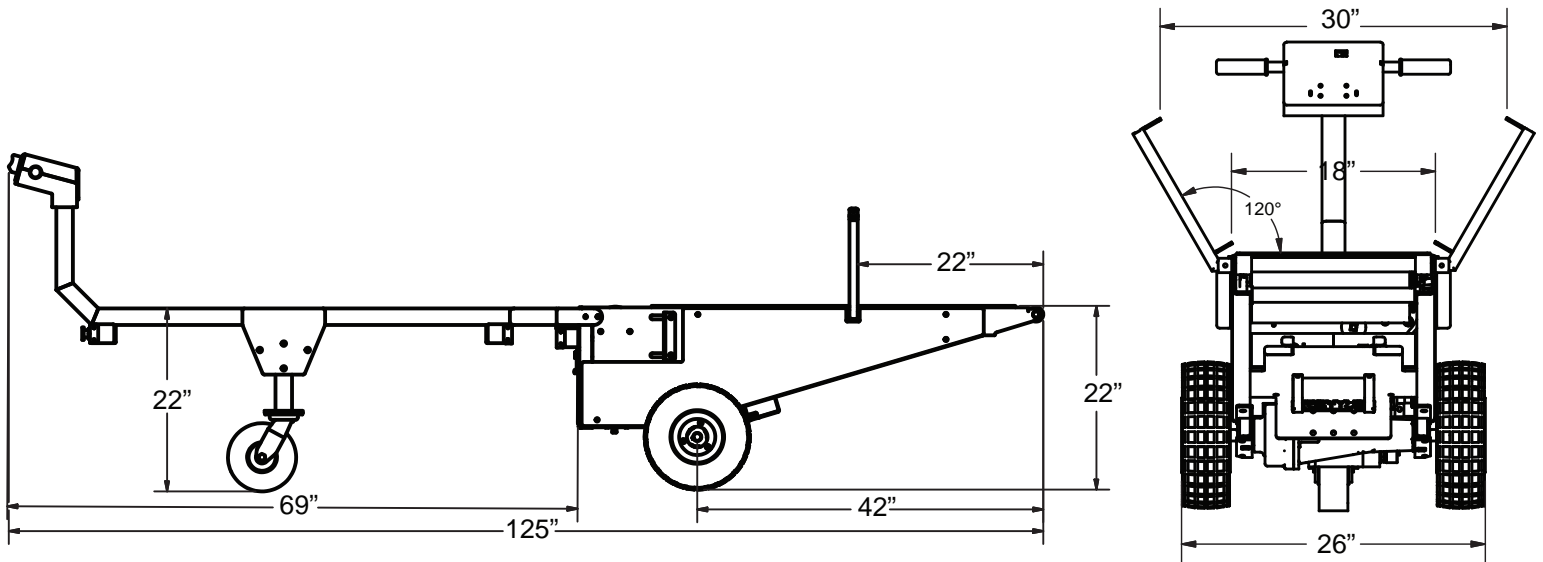

CarpetCaddy Standard Features

- Heavy Duty Steel Frame
- 800 lb. Diff/ Transaxle
- High Tech Speed Controller
- Neutral Throttle Braking
- Adjustable Acceleration/Braking
- 24v(2) 35 Amp Sealed Batteries
- Variable Speed Twist Grip for Power Drive and Loading Belt
- Non-Marking Rubber Tires
- Battery Gauge
- Internal Automatic Trickle Charger
- 2 Adjustable Plastic Guide Rollers
- Hinged Removable Handle

CarpetCaddy Options

CarpetCaddy (500 lbs loading capacity)

Extended Run Time Batteries (Qty: 2 85 a/h)

Upgrade to 1000 lbs loading capacity
(Includes 36 volt motor/transaxle/controller, loading gear box and ex. battery)

Extra Set of Adjustable Plastic Guide Rollers

Foam Filled Tires

Safety Stop Switches (Qty: 2)

Safety Horn

Onboard, Faster, Weather Proof Charger

Foam Filled 12" Ag Tread Tires

Foam Filled 16" Ag Tread Tires

These options are only recommendations. Please consult a Sales Engineer at DJ Products, Inc. for your specific application. Other options are available.