

TrailerCaddy™

15K Lift - 48v

**The Walk Behind, Battery Powered Trailer Mover.
Move Heavy Trailers With Ease!**



Lifts tongue weight up to 15,000 lbs
Pushes or pulls up to 100,000* lbs
Optional Air Brake Release Package Available
**Zero Grade Smooth Surface Rating*

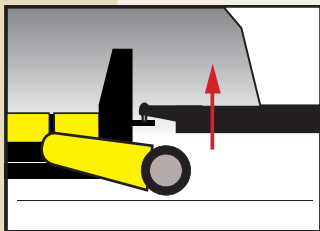

**Lifts and Moves Standard
Ball and Pintle Coupler
Trailers.**

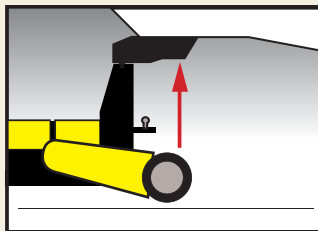

**Lifts and Moves King Pin
and Goose Neck Style
Coupler Trailers.**

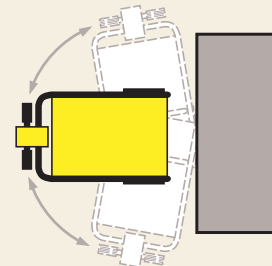

**Lifts and Moves Heavy
Campers, Boats, Utility,
Generators or Equipment
Trailers!**

DJ PRODUCTS, INC.

1009 4th St. NW, Little Falls, MN 56345 • PH: 800-686-2651 • FAX: 320-632-3553 • www.djproducts.com

TrailerCaddy™

15K Lift - 48v

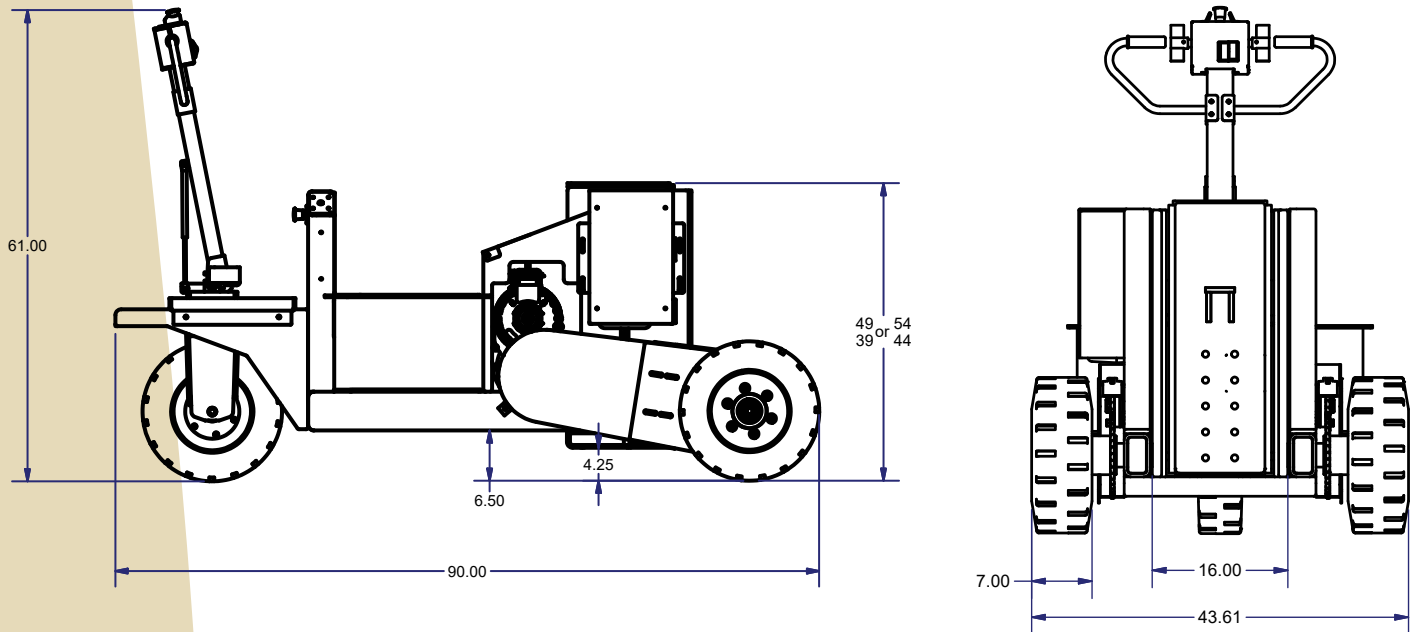

TrailerCaddy 15K Lift - 48v Standard Features

- Heavy Duty Steel Frame
- 48v Transaxle
- 4.6:1 Gear Reduction with Chain to Drive Tires
- High Tech Speed Controller
- Neutral Throttle Braking
- Adjustable Acceleration/Braking
- 15,000 lbs 10" Hydraulic Pump Lift Kit
- 48v(4) 150 Amp Batteries
- Variable Speed Twist Grip
- 0-2 mph Forward/Reverse
- Battery Discharge Indicator
- External Charger
- Safety Stop Switch
- Safety Horn
- (2) 18" Solid Tread Drive Tires (7"w)
- (1) 18" Solid Tread Steer Tire (4 1/2"w)

TrailerCaddy 15K Lift - 48v Options

- TrailerCaddy 15K Lift - 48v
- King Pin Attachment for 5th Wheel Trailers
- Upgrade to Dual 18" Steer Wheels
- Air Brake Release Kit
(includes pump motor, cables & 5 gal. air tank)
- Pintle Hitch
- Ball Hitch and Bracket
- Safety Strobe Flashing Light
- King Pin Lighting Kit
- Foot Path Lighting Kit
- Extended 10" Lift Kit (brings total lift to 20")
- Upgrade to 24" Hydraulic Pump Lift Kit
(Cannot be used with King Pin, only with Pintle or Ball Hitch)
- Upgrade to Qty: (8) 150 Amp Batteries
- Upgrade to Qty: 110 Amp AGM Batteries (Set of 4)
- Upgrade to Qty: (8) 110 Amp AGM Batteries
(AGM batteries needed for overseas shipments)

These options are only recommendations. Please consult a Sales Engineer at DJ Products, Inc. for your specific application. Other options are available.



Ireland/UK Importer: Brightgreen Recycling Ltd,
Fleenstown, The Ward, Co. Dublin DT11 ET71, Ireland.
Ph: +353 86 3881615 E: aidan@brightgreen.ie

1009 4th St. NW, Little Falls, MN 56345 PH: 800-686-2651 • FAX: 320-632-3553

www.djproducts.com