

# ***CartCaddyHD*** **ChainDrive** <sup>TM</sup>

Prevents physical strain and pain associated with pushing or pulling heavy carts and other wheeled equipment.

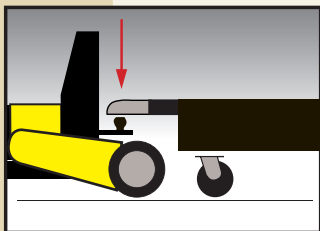

**Push or Pull up to 50,000 lbs**



Firm attachment to cart transfers weight to wheels of CartCaddyHD Chain Drive.

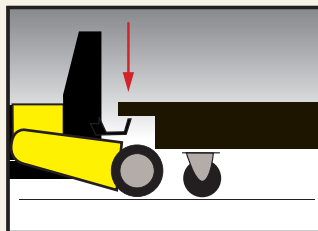

CartCaddyHD Chain Drive hydraulic lift kit raises and lowers for quick connection to carts on rails.

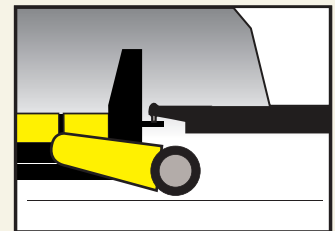

CartCaddyHD Chain Drive easily pushes and pulls trailers with ball hitch.

**DJ PRODUCTS**, INC.

1009 4th St. NW, Little Falls, MN 56345 • PH: 800-686-2651 • FAX: 320-632-3553 • [www.djproducts.com](http://www.djproducts.com)

# CartCaddyHD<sup>TM</sup>

## ChainDrive

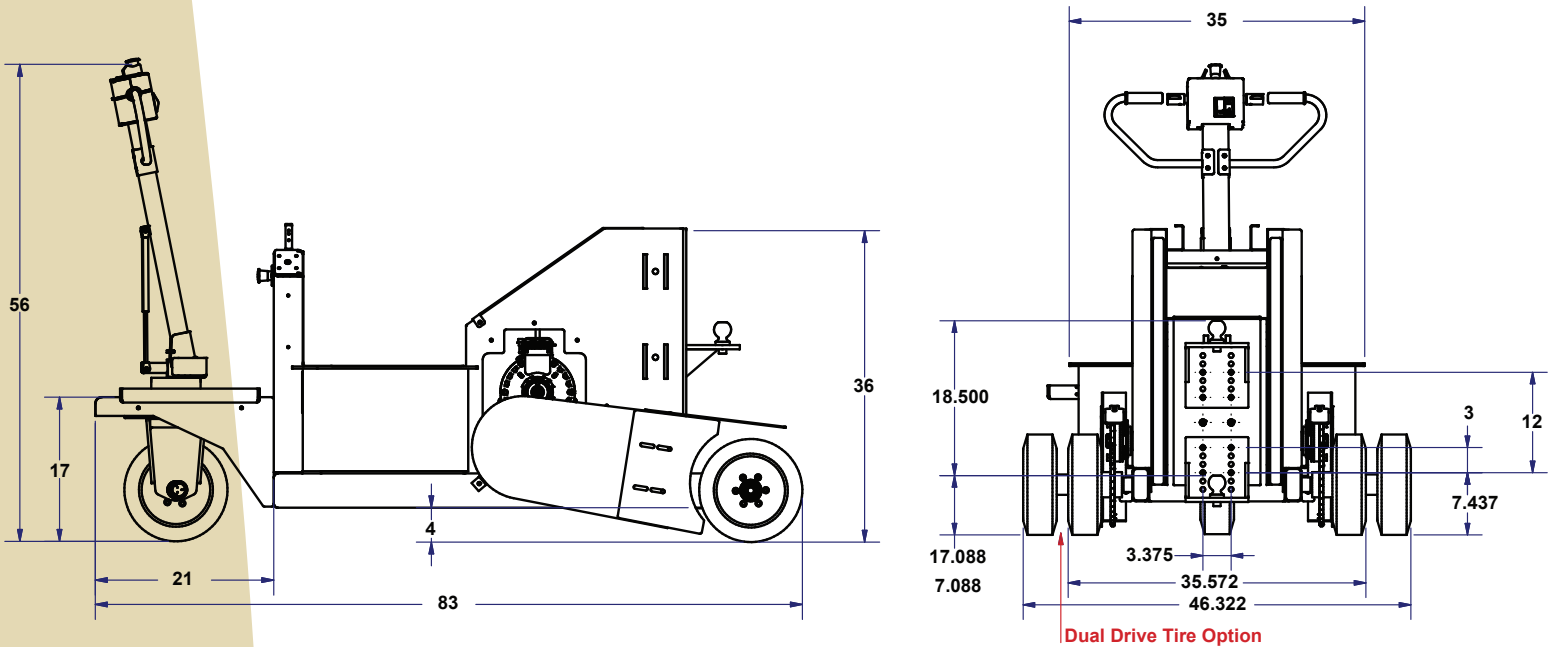

### CartCaddyHD Chain Drive Standard Features

- Heavy Duty Steel Frame
- 2000 lb. Differential / Transaxle
- 2:1 Gear Reduction with Chain to Drive Tires
- High Tech Speed Controller
- Neutral Throttle Braking
- Adjustable Acceleration/Braking
- 5000 lbs Hydraulic Actuator Lift Kit
- 36v(3) 115 Amp Batteries
- Variable Speed Twist Grip
- 0-2.86 mph Fwd/Rev (23 tooth gears)
- Battery Discharge Indicator
- Onboard Charger
- Safety Stop Switch
- (3) Solid Fork Truck Drive Tires

### CartCaddyHD Chain Drive Options

- CartCaddyHD Chain Drive
- Ball Hitch and Steel Mounting Bracket
- Safety Horn
- Maintenance Free Batteries
- Pintle Hitch
- Flashing Light and Pole
- 9 Tooth gears increases torque 2.5x reduces speed
- Trojan Batteries (150 amp/hr)
- Sealed AGM Batteries (110 amp/hr)
- Fully Enclosed Chain Guards
- Dual Solid Drive Tires

These options are only recommendations. Please consult a Sales Engineer at DJ Products, Inc. for your specific application. Other options are available.