

TrailerCaddy

Terminal Tractor / 30K Lift - 48v



Battery-powered TrailerCaddy moves empty and loaded trailers in and out of dock areas or tightly-confined spaces in a moment's notice

DJ PRODUCTS, INC.

1009 4th St. NW, Little Falls, MN 56345 • PH: 800-686-2651 • FAX: 320-632-3553 • www.djproducts.com

TrailerCaddy™

Terminal Tractor / 30K Lift - 48v

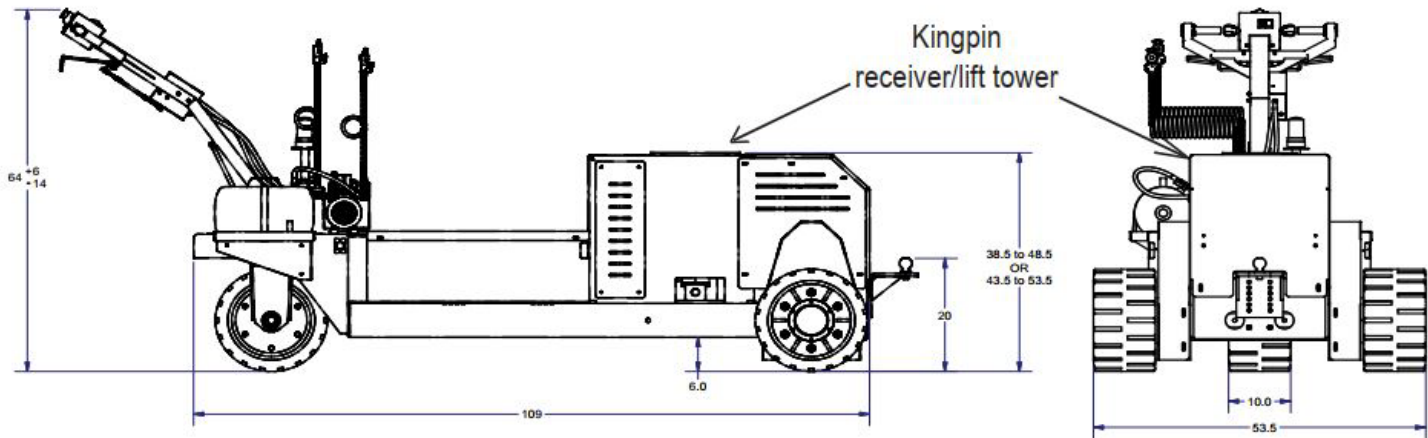

TrailerCaddy Operation: Position the kingpin receiver/lift tower directly below the kingpin of the trailer. Engage the hydraulic lift to raise the front end of the trailer off the ground. Press butterfly throttle control forward or backward to move trailer.

TrailerCaddy Terminal Tractor Standard Features

- Heavy Duty Steel Frame
- 6.5 HP Motor / Differential Transaxle
- 6:1 Gear Reduction with Chain to Drive Tires
- AC Digital Controller
- Master Disconnect
- Audible 30k Overload Alarm
- Neutral Throttle Braking
- Adjustable Acceleration/Braking
- 10" Hydraulic Pump Lift Kit
- 48v (4) 150 Amp/hr Batteries
- Variable Speed Thumb Twist Pad
- 0-1.6 mph Variable Forward/ Reverse
- Battery Discharge Indicator
- External Charger
- Safety Stop Switch
- Safety Horn
- Safety Strobe Flashing Light
- (2) 18" Solid Tread Drive Tires
- (1) 18" Solid Tread Steer Tires
- HD King Pin Receiver for 5th Wheel Trailer

TrailerCaddy Terminal Tractor Options

TrailerCaddy TT 48V

Pintle Hitch

Ball Hitch and Bracket 3,000 lbs capacity

Air Break Release Kit With E-Stop Dumping and Trailer Service Break Lever (includes pump, Glad Hand cables, & 5 Gal. airtank)

Safety Light w/ Pole, max length 15"

King Pin Lighting Kit

Foot Path Lighting Kit

Upgrade to Qty: (8) 150 Amp Batteries

Upgrade to Qty: (8) 110 Amp Batteries
(AGM batteries needed for overseas shipments)

Upgrade to Qty: (16) 150 Amp Batteries

Upgrade to Qty: (16) 110 Amp Batteries
(AGM batteries needed for overseas shipments)

These options are only recommendations. Please consult a Sales Engineer at DJ Products, Inc. for your specific application. Other options are available.

Ireland/UK Importer: Brightgreen Recycling Ltd,
Fleenstown, The Ward, Co. Dublin DT11 ET71, Ireland.
Ph: +353 86 3881615 E: aidan@brightgreen.ie

DJ PRODUCTS, INC.

1009 4th St. NW, Little Falls, MN 56345 • PH: 800-686-2651 • FAX: 320-632-3553 • www.djproducts.com